



# STARK

STRONGLY CHOSEN

SINCE 1980

## STARK LHA RUNWAY LIGHTBAR SWEEPER



SPECIAL  
APPLICATION

- Professional equipment for efficient cleaning of runway lightbars.
- Finnish quality and best components.
- The sweeper can be fitted to wheel loaders or tractor front or rear 3 point linkage.
- Robust framework made of high quality structural steel and components from leading European manufacturers ensure reliability, efficiency and durability in operation Hydraulic components are designed for use at low temperatures Optimized weight distribution and balancing.
- The optimized blade angle and geometry of the wings contribute to the effective removal of snow to the both sides, reduce the resistance of the mass of snow and reduce fuel consumption.
- The original design provides an excellent view to the working brushes and the wings The absence of structural elements in the field of view facilitates the work of the operator and prevents damage to the signal lights.
- Accurate and quick opening of the front wings, stepless adjustment of the rotation speed of the brushes and soft bristles allow cleaning quickly and carefully.

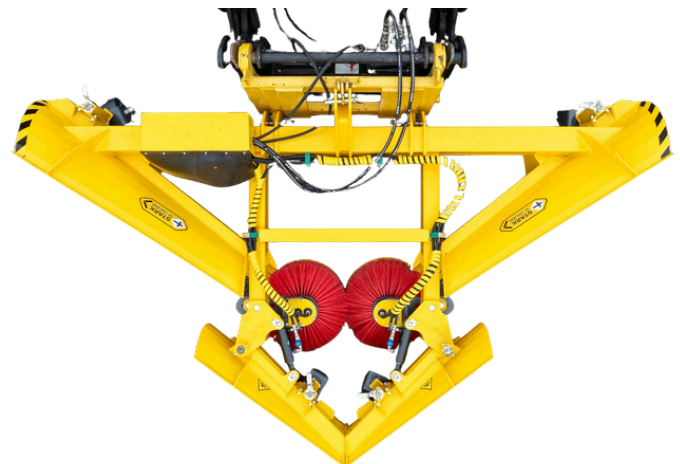
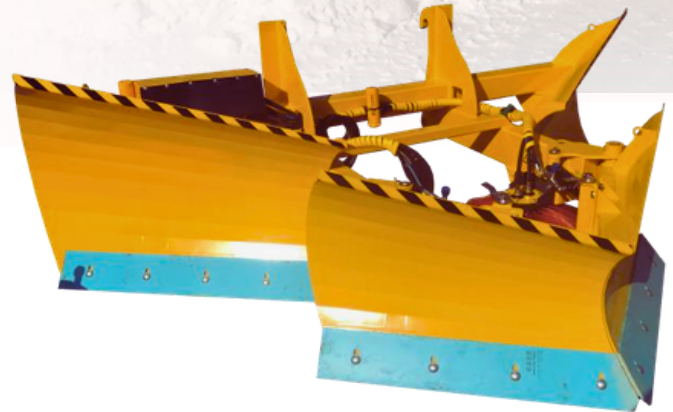

### STANDARD EQUIPMENT

- ▶ 3 point linkage cat 2/3 or Volvo BM fittings
- ▶ Mechanical adjustment of the brushes
- ▶ Oil flow speed controller for brushes
- ▶ Two pairs of support legs with rotating skids
- ▶ 4 hydraulic hoses to the base machine
- ▶ Flat steel blades 500 HB
- ▶ Hazard taping

### OPTIONAL EQUIPMENT

- ▶ Two pairs of support wheels
- ▶ Electric valve 12 or 24 V for connecting by 2
- ▶ Hydraulic hoses to the base machine
- ▶ Control unit with wiring kit 12/24 V
- ▶ Perforated or rubberized perforated blades 500 HB
- ▶ Polypropylene wear resistant blades

STARK

[www.stark.fi](http://www.stark.fi)  
STARK / Lametal Oy

## TECHNICAL DRAWINGS

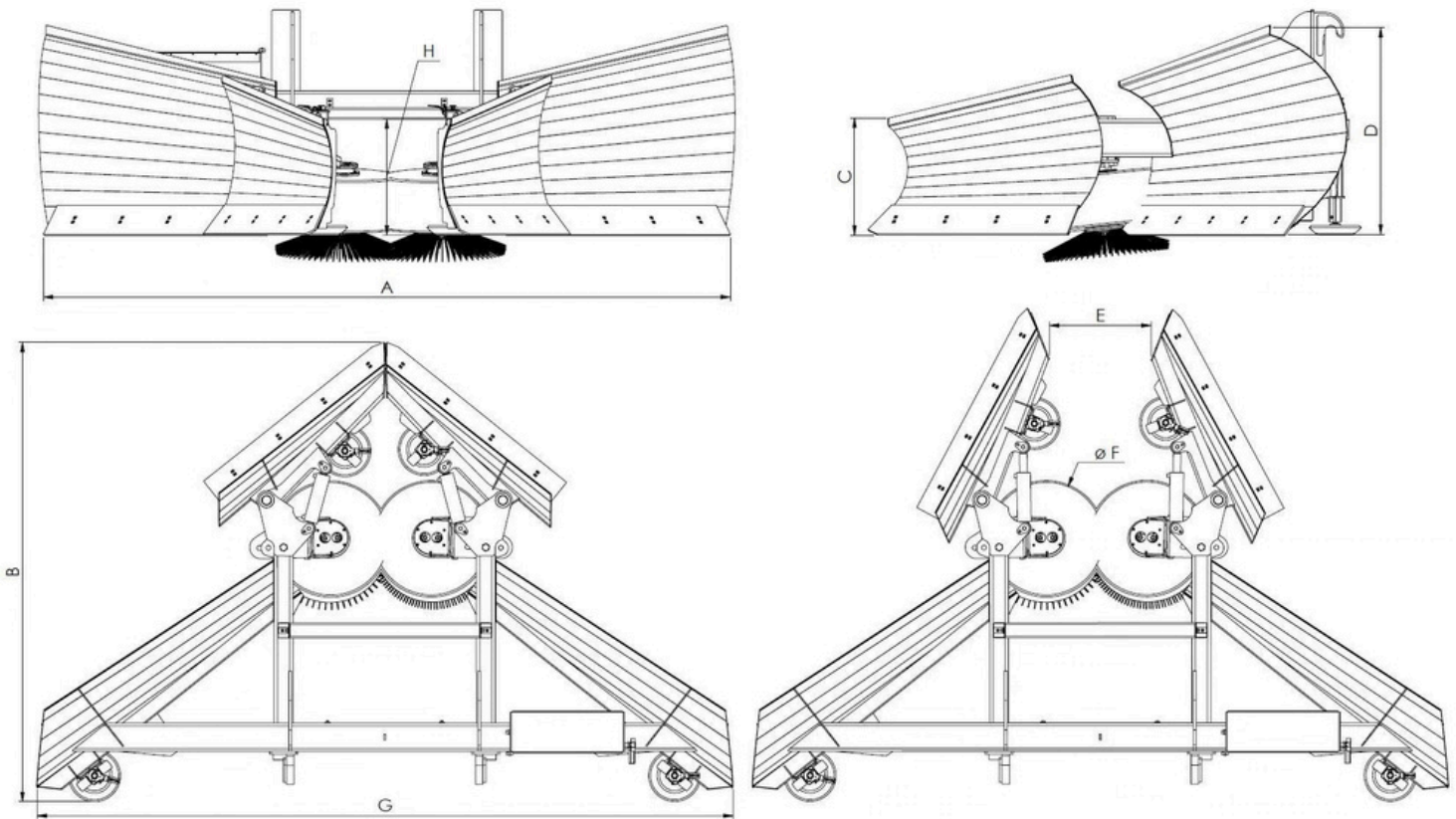

## TECHNICAL DIMENSIONS

Product	Working width (mm)	Overall length (mm)	Min. wing height (mm)	Max. wing height (mm)	Wedge opening width (mm)	Bristle diameter (mm)	Overall width (mm)	Ground clearance (mm)	Min. oil demand (l/min)	Max. oil supply (l/min)	Max. pressure (bar)	* Weight (kg)
	A	B	C	D	E	F	G	H				
LHA 3600	3630	2430	620	1100	540	600/700	3680	3680	40	100	300	990

\*\* Weight may vary slightly depending on the configuration.