



STARK

STRONGLY CHOSEN

SINCE 1980

STARK BSW BUCKET SWEEPERS



SWEEPING

- **Designed specifically for machines weighing over 8 tons.**
- **Massive water tank.**
- **Very spacious bucket.**
- Bucket lip made of HB500 grade wear-resisting steel.
- Bolt-on standard blades and edge wear pieces protect the bucket from wear and tear.
- Adjustable brush height and hardened supporting rollers improve efficiency and comfort of use.
- Patented Ecoline Sunline 900 mm lamellas for better results and long-lasting performance.
- Large hopper volume reduces emptying intervals.
- Large opening angle allows a full unloading angle.
- Hydraulic motor is integrated inside the brush roller for protection against impact.
- Buffer-equipped coupling protects the hydraulic motor of the brush roller in all situations.
- Massive one-piece water tank extends refilling cycles.
- The DRM technology dampened and bushed brush disc roller protects the hydraulic motor when it starts and stops, offering it a longer life.



STANDARD EQUIPMENT

- ▶ 2- or 4-hose or electronically controlled hydraulics
- ▶ Stark-Fit adapters
- ▶ Hardened Support Rolls

ACCESSORIES

- ▶ Pin Float floating frame, vertical and horizontal
- ▶ High-pressure dust suppression
- ▶ High-pressure washing device
- ▶ Side sweeper(s)



STARK

WWW.STARK.FI
STARK / LAMETAL OY

TECHNICAL DRAWINGS

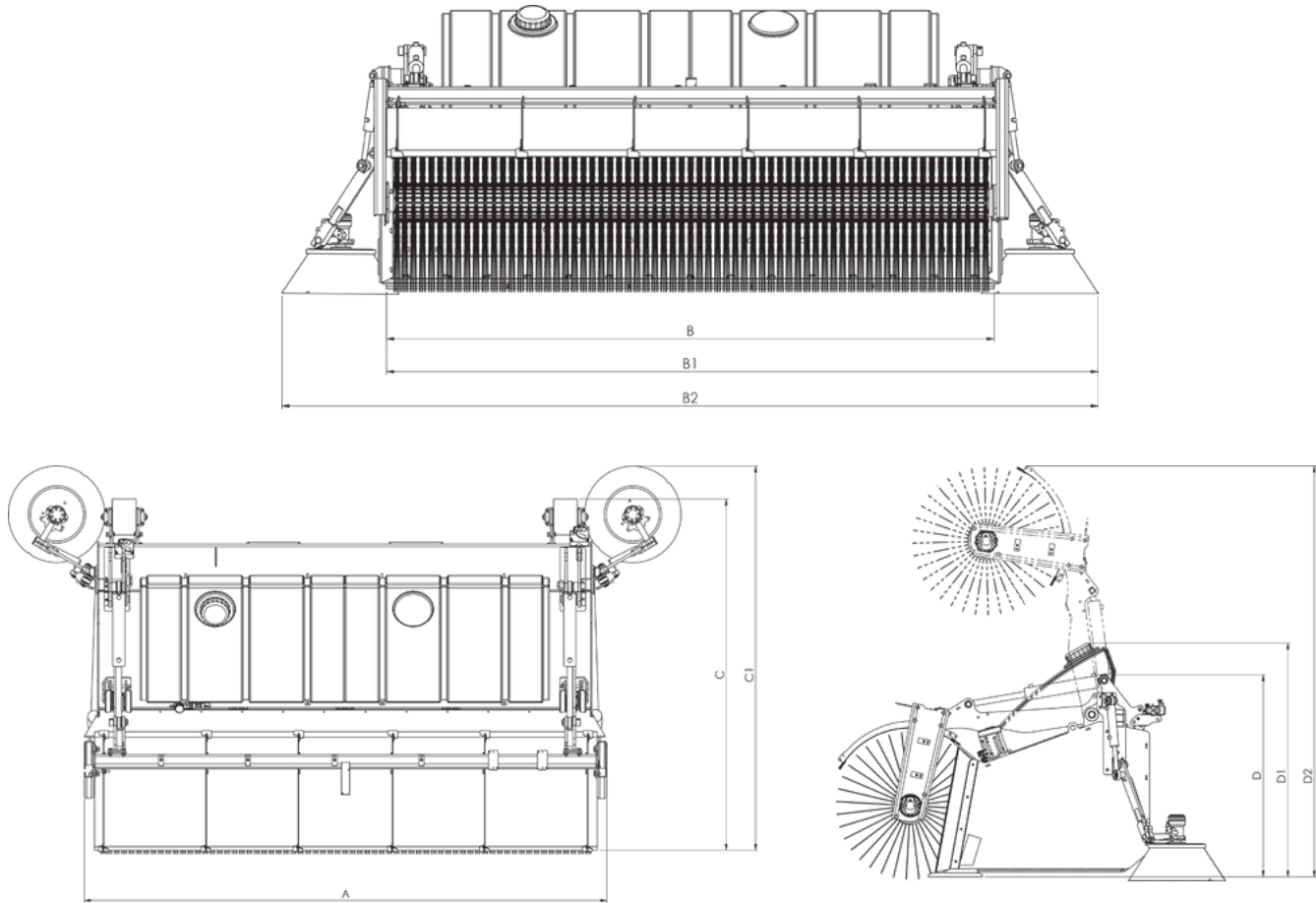

TECHNICAL DIMENSIONS

Product	Max. width (mm)	Working width (mm)	Max. working width with one side sweeper (mm)	Max. working width with two side sweepers (mm)	Length (mm)	Length with side sweeper (mm)	Height (mm)	Height with water tank (mm)	Height open (mm)	Bucket volume (m ³)	Water tank (l)
	A	B	B1	B2	C	C1	D	D1	D2		
BSW 2200	2190	1990	2550	3120	2150	2350	1230	1430	2510	1,6	250
BSW 2500	2690	2490	3050	3620	2150	2350	1230	1430	2510	2,0	480
BSW 3000	3190	2990	3550	4120	2150	2350	1230	1430	2510	2,4	600

* Weight varies depending on adapter type / brush equipment.